



Making Them Work

Primary-Secondary Chilled Water Systems

By Steven C. Severini, P.E., Member ASHRAE

Despite the recent scrutiny and criticism of primary-secondary chilled water pumping systems, many owners still decide these systems are appropriate for their facility. Factors such as simplicity, familiarity, and experience are considered, in some cases, to have benefits to the owner that overshadow efficiency and first costs. Primary-secondary pumping is not appropriate for all projects, but when the decision has been made to use it, properly addressing technical aspects of such designs and adequately addressing facility users' needs significantly contributes to the project's success. This article explores key issues to consider when designing a primary-secondary chilled water plant.

Discuss This Article



Look and Listen

Learning the objectives and goals of owners and facility users is vital during the programming phase of any project. What engineers may not know is that reviewing the owner's existing facilities and learning what systems and equipment types are familiar to building operators also are important.

Owners and operators like to be familiar with the new chiller plant systems. (They also like to avoid past problems!) Interviewing building maintenance personnel can be a big help. They typically

About the Author

Steven C. Severini, P.E., is an associate partner at Newcomb & Boyd in Atlanta.

are eager to provide input and can give considerable insight into how well the new system will be maintained and operated. Knowing this information can assist engineers in designing systems tailored to user needs and increases chances for satisfying a client.

For example, during field investigation for a facility's new chiller plant, a conversation with the maintenance staff person responsible for cleaning and chemically treating the existing cooling towers revealed that the existing towers' design prevented complete draining. For the new cooling towers, he wanted a small drain valve on the cooling tower side of the discharge isolation valve to allow complete draining of the tower during wash down. This small item was added to the design, which made the maintenance person feel he had contributed. When facility managers and decision-makers hear that the guys in the trenches have positive comments on the new design, it reflects well on design engineers.

Teach Others

When owners are faced with a new chiller plant containing the latest technology, such as variable speed chillers, advanced communications and software, or thermal storage, they are concerned with how their maintenance group will respond to operating this new equipment. The first step in managing this challenge is having significant user involvement in the design, as discussed earlier. Another key step is providing sufficient owner instruction and training during the design and commissioning phases.

Training for the overall system operation can be conducted by engineers in a classroom setting. Two identical sessions are recommended to accommodate all necessary personnel. Remember, your audience is operating and maintaining a facility. It is impossible to present to the entire group in a single session without staff leaving to respond to the latest crisis.

These sessions should focus on general design intent and system operation. Factory-trained representatives from equipment manufacturers should lead the instruction for more detailed equipment information. They can best address preventive maintenance plans and necessary troubleshooting strategies. Sessions can last several hours for more complicated equipment, such as chillers and the building automation system. By the time the new chiller plant is commissioned and ready to be used, the maintenance group should be well schooled and prepared to tackle everyday life in the new plant.¹

Delta T

After knowing the required plant tonnage, probably no single piece of information is more important to chiller and pump selections than the design temperature differential between the supply and return chilled water. Many articles have discussed this issue for good reason. Over- or underestimating the actual ΔT can cause operating inefficiencies and insufficient chilled water flow to building cooling coil loads.²

For new chiller plants serving existing cooling coils, it is necessary to determine the actual ΔT produced by the existing coils. This likely differs from the ΔT for which the coils were selected due to a variety of reasons. If the actual ΔT on a design day is more than 1°F or 2°F (0.6°C or 1.1°C) less than the ΔT for which the coils were selected, then there is a problem and remedial action to fix that problem is strongly recommended. This could involve cleaning coils, retuning control loops, replacing three-way valves with two-way valves, or decreasing chilled water supply temperature.

After the actual ΔT is established, it is prudent to select the range for the chiller evaporators and flow rate for the primary pumps for a ΔT that is 2°F (1.1°C) less than the actual ΔT being produced by the loads. This is done as a measure of safety to ensure that there is adequate flow for the loads. Even for new chiller plants serving new cooling coils, selecting chiller and pumps for a ΔT that is 2°F (1.1°C) less than the cooling coil design ΔT has worked very well. A typical evaporator range is 54°F (12°C) entering water temperature and 42°F (5.5°C) leaving water temperature (12°F [6.6°C] ΔT) for a chiller plant serving cooling coils that have been selected for 14°F (7.8°C) ΔT .

While the intent of this article is not to include a complete discussion of the problems associated with a system that does not produce a ΔT that is equal to the design ΔT of the chillers ("low ΔT syndrome"), it is important to note that a low ΔT condition significantly reduces the impact on the efficiency of the chiller plant, regardless of the pumping system being used.

Primary Pumps: Manifold or Dedicated?

Manifolded primary pumps (pumps that are headered together on the discharge side before entering any chillers [Figure 1]), can be desirable for a few reasons. First, they give users the ability to operate any chiller with any primary chilled water pump. This helps whenever a single pump is down for maintenance because a pump outage does not correspond to a particular chiller.

Also, manifolded pumps give users the ability to operate more than one pump for a single chiller. This can help solve a low ΔT problem by increasing primary flow and forcing a chiller to a greater load when the return temperature is less than design. Some systems have a control valve on the chiller evaporator in conjunction with manifolded primary pumps to balance flow between chillers and keep constant flow to each chiller. This works well for balancing flow, but interferes with the benefit of allowing additional flow, if desired, to counteract a system's low ΔT .

A problem with manifolded pumps is that an entire chiller plant can fail due to a single pump's failure. Here's how: consider a typical plant with three chillers and three manifolded primary pumps, with two chillers and two pumps operating. If a single pump fails, the flow rate to each chiller drops substantially at the moment of pump failure. This sudden drop in evapo-

rator flow trips each chiller's flow switch and causes failure of both chillers. A misconception exists that manifolded pumps allow for a backup pump to start upon a lead pump failure (thereby maintaining chiller plant operation). On the contrary, the author's experience has been that the evaporator flow switches shut down the chillers before the software of the building control system determines the pump failure and starts the backup pump. There may be a creative solution to this, but if not addressed, this is a strong reason not to use a manifolded primary pump arrangement.

Dedicated primary pumps (each pump is dedicated to a single chiller by direct piping [Figure 2]) are used, in part, because of the simple nature of the chiller plant operation. It is easy to understand that because Pump 1 is piped directly to Chiller 1, whenever that chiller is operating its dedicated pump should be operating. Even though this seems inconsequential, simpler often is better. Building operators find this simplicity beneficial, particularly during crisis management.

Another benefit of dedicated pumps is that they can handle unequally sized chillers without using control valves and flow measurement devices to balance the correct flow to each chiller. Again, simpler is better.

The downside to dedicated pumps is that a standby pump cannot be started automatically by the building control system, but instead needs manual intervention. This can present a problem with chiller plants that do not have standby capacity.

On the positive side, a primary advantage of dedicated pumps is that a single pump failure only causes one chiller's failure, not multiple chillers.

Decoupler Bridge

The traditional philosophy for designing the decoupler bridge (the common piping between the primary and secondary piping loops) is to have a minimum amount of pressure drop in this common piping. The goal for having minimum pressure drop is to create two loops that are entirely "decoupled," which means that a change in flow rate in one loop does not affect the flow rate in the other (because the only interface between loops is this common piping that has negligible pressure drop). Some engineers believe this traditional philosophy is necessary in primary-secondary chilled water systems. That is, the decoupler bridge should have minimum pressure drop by being short and without any valves and obstructions.

Another philosophy is that pressure drop in the decoupler bridge is acceptable, and can even be beneficial to the chiller plant operation. Here's how: first of all, the control sequence

for the chiller plant likely requires knowing the flow rate in the decoupler bridge.

The decoupler flow rate is an indicator of excess chiller capacity and can be used to disable active chillers not required to meet the current demand. (However, flow rate is not a good indicator of when to enable additional chillers.)

Regardless of the method of flow measurement, it is true that the greater the water velocity and more uniform the flow profile, the more accurately a device can measure the flow rate. For this reason, the author typically reduces the pipe size in the decoupler to obtain 15 to 25 fps (4.6 to 7.6 m/s) water velocity based on the design evaporator flow of one chiller, and routes this piping to have 15 pipe diameters of straight pipe. (Some flow measurement device manufacturers may say this is unnecessary, but all should say that doing this improves accuracy.) The reduced pipe size creates a pressure drop, but the secondary loop inherently overcomes this

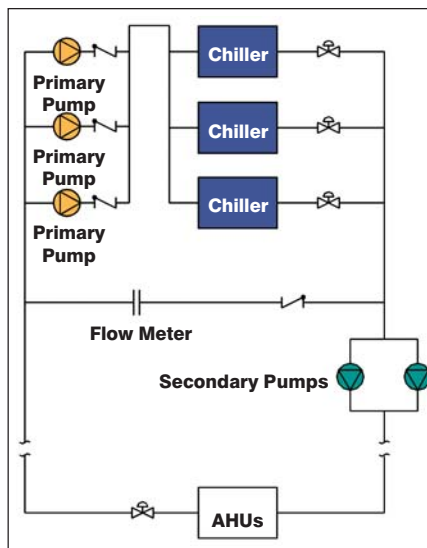

Figure 1: Primary-secondary with manifolded pumps.

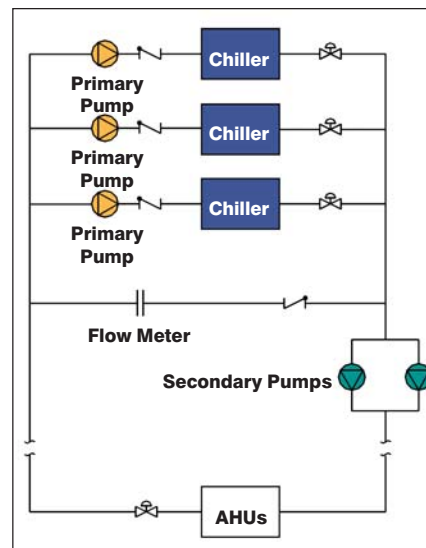

Figure 2: Primary-secondary with dedicated pumps.

pressure drop through the differential pressure control of the secondary pump speed. The current technology of chiller controls allows the primary loop to handle small variations in flow. The result is that a reduced decoupler pipe size is not a problem and offers better accuracy.

A second issue related to pressure drop in the decoupler is whether or not a check valve is appropriate. The author's philosophy for design and operation of primary-secondary chiller plants includes a check valve, and has been successful in many chiller plants. Two primary reasons exist for this:

1. A check valve forces the secondary pumps in series with the primary pumps when secondary pump speed and flow is increasing beyond the capacity of the primary pumps. This often occurs during a part-load situation when the system ΔT is less than the chiller design. (In theory, this should not happen but often does.) The check valve allows the secondary pumps to

“help” pump the primary loop and push additional flow through chiller evaporators above their design rate. This additional flow will force load the chiller to 100% during a situation when the chiller ΔT is less than design, or greater than 100% if this condition coincides with low outdoor wet-bulb temperatures.

The major benefit is that an additional chiller is not brought on-line simply to provide additional primary water flow. It is brought on-line when the active chillers are more fully loaded.

One of the best ways to reduce plant energy consumption is to keep the quantity of active chillers matched to the system load. A check valve helps to do this.*

2. A check valve also prohibits return water from “contaminating” the supply water by increasing its temperature and, therefore, hindering its ability to provide dehumidification at the cooling coils. Also, supplying chilled water at 43°F (6°C) to a system designed for 40°F (4.4°C) will cause required system flow to increase and ΔT to correspondingly decrease.² In short, flow in the reverse primary direction in a decoupler bridge is usually not good, and a check valve prevents it.

An issue that must be addressed within the design of a system that uses a decoupler bridge check valve is the potential

* This discussion applies to constant speed chillers. Variable speed chillers have different part-load characteristics. And, staging chillers on prior to being fully loaded can be beneficial.³

dead-head condition of the secondary pumps if no primary pumps are operating. During this condition, the secondary pump speed escalates in response to the differential pressure sensor out in the system, which senses zero differential because no secondary flow exists. One approach to resolving this problem is to require proof of operation of at least one primary pump for any secondary pump to operate. Upon loss of proof of operation of all primary pumps, the secondary pumps stop. A further measure is to install a high-pressure safety on the discharge of the secondary pumps.

The location of the decoupler bridge can be used to create preferential loading of certain chillers within a single plant. Although in many plants, particularly those with identical chillers, it is most desirable to equally load active chillers, a hybrid chiller plant may perform more efficiently if certain chillers are base loaded. An example is a plant consisting of one steam absorption chiller and two or three electric centrifugal chillers (*Figure 3*).

Because absorption chillers operate better when their load is constant, the decoupler bridge can be positioned to connect to the primary return header downstream of the absorption chiller. Doing this causes the absorption chiller to only see system return water, not a blend of system return water and excess primary flow from the decoupler bridge. This increases the

proportion of the total load being experienced by the absorption chiller to above that experienced by the other chillers. Of course, it would be preferable for the absorption chiller, which favors a constant load, not to be the lead chiller in such a scenario (because of the varying load experienced by a lead chiller when it is the only chiller active).

Secondary Pump Operation

The primary goal of the secondary pump system is to deliver flow to cooling loads by maintaining a differential setpoint at one or more locations in the distribution system. While this goal is common, the method can vary. Simply operating the lead pump to full capacity before energizing another pump can lead to overloading the pump motor (or oversizing the motor) and less-than-optimum energy efficiency. Another approach uses a pumping control strategy that optimizes pump sequencing and speed by considering pump efficiency, motor efficiency, the flow vs. head system curve, and other pump and system parameters. Software is available that stages the secondary pumps to minimize pump horsepower and ensure that nameplate motor horsepower is never exceeded. Bearing in mind that a primary-secondary system was chosen perhaps because of its simplicity, introducing complexity in the pump operation must be considered carefully. However, doing so results in more efficient system operation.

Expansion Tank Connection

Common engineering practice is to connect the expansion tank to the suction side of the system pump. This establishes the point of “no pressure change” in the system because of the compressible nature of the air cushion within the tank. The pressure only can change at this location if a change in system volume occurs, such as during a system shutdown when an expansion of the system volume occurs due to a temperature rise.

The often-used term “point of no pressure change” means that the starting and stopping of the pump should not alter the pressure at this location. This common practice of expansion tank connection on the suction side of pumps is not easily applied to primary-secondary pumping systems simply because there are two sets of pumps. Which pumps should receive the expansion tank connection?

The best connection location for an expansion tank can vary depending on the static height of the system, the head of the secondary pumps, whether or not there are tertiary pumps located at buildings, and other factors.⁴ For example, in a new

chiller plant being connected to existing buildings previously served by local building chillers, one must be mindful not to create a situation on the discharge of the building pumps where the pressure exceeds the pressure class of the existing piping system. This can happen because the static head at each building has become a function of the worst-case building connected to the system, whereas previously the static pressure at that location was determined by only the height of that building.

Therefore, the “best location” may not even be within the chiller plant, but out within the system or at the top of the highest building. Nevertheless, assuming all factors have been considered and the “best location” is within the chiller plant, which pumps should connect to the expansion tank? The answer is still not definitive, but the author’s experience indicates that connecting to the primary

pumps is best. This location provides a more unencumbered connection to the system. Fewer obstructions exist, such as a decoupler check valve, evaporator isolation valve, or check valve on the discharge of the secondary pumps, that could prohibit the expanding system water volume from reaching the expansion tank.

Summary

Successful primary-secondary systems are being designed with the support of building owners and engineers. Regardless of the pumping system type, active listening by the engineer during programming and design, continuous owner involvement, and teaching others through formal and informal training

sessions can promote satisfaction of a completed project. Although new technologies and equipment improve over time and change design philosophies, the issues presented in this article are important to primary-secondary systems as they are designed today.

References

1. Georgia State Financing and Investment Commission. 2002. “Building commissioning interim recommended guidelines.” Final draft July.
2. Kirsner, W. 1995. “Troubleshooting chilled water distribution problems at the NASA Johnson Space Center.” *Heating/Piping/Air Conditioning* (2).
3. Taylor, S. 2003. “Primary-only vs. primary-secondary variable flow systems.” *ASHRAE Journal* 44(2):25–29.
4. Taylor, S. 2003. “Understanding expansion tanks.” *ASHRAE Journal* 45(3):24–31.

Bibliography

- Avery, G. 2001. “Improving the efficiency of chilled water plants.” *ASHRAE Journal* 43(5): 14–18. ●

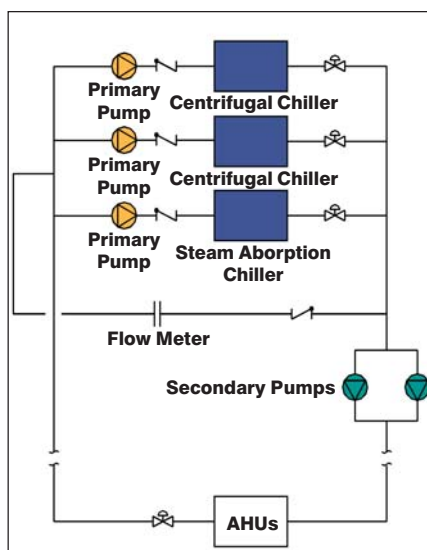

Figure 3: Decoupler bridge for preferential loading.